

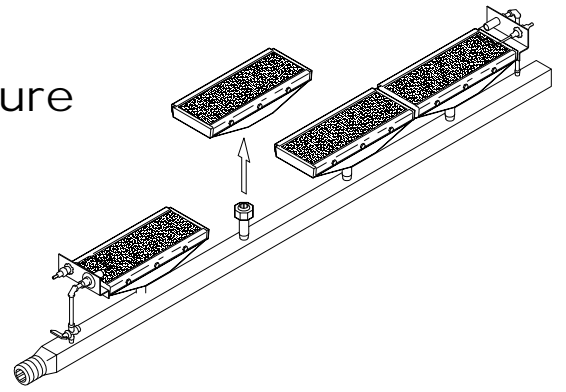

MR-12 Refractory Replacement Procedure

1. Remove burner section from manifold to enable proper and complete cleaning and rebuilding.



2. Remove HD-12 Hold-Down Rails.

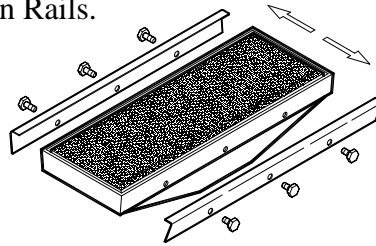

3. Remove Metal Refractory and gasket material. Make sure to thoroughly clean all gasket material from housing. Shake out any debris that may have fallen under the deflector plate.

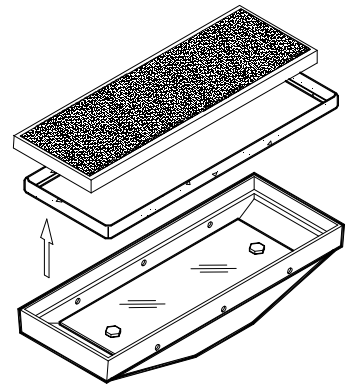

4. Apply contact cement evenly along the walls and ledge of the refractory seat.

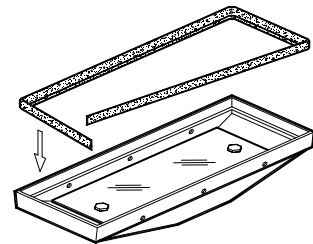

5. Set the gasket in place starting in one corner and pressing in along the seating surface. The gasket should line the wall and ledge for an effective seal.

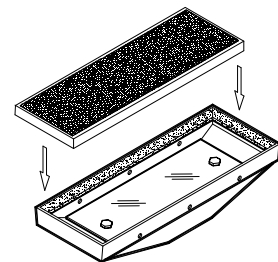

6. Place new metal refractory on the gasket seat. Push down gently centering the refractory into the seat.

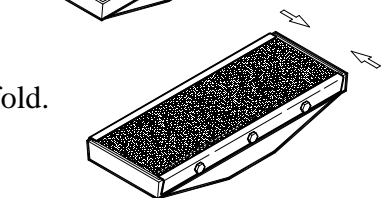

7. Replace the hold down rails and install properly back onto manifold.